

B I O G A S

REJECT WATER TREATMENT

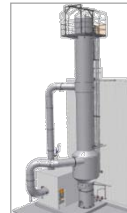

EPCON EVAPORATION TECHNOLOGY AS

EVAPORATORS – DRYERS – DISTILLATION & DEHYDRATION – HEAT RECOVERY SYSTEMS
ENGINEERING AND AFTERSALES SERVICES

EPCON products

EPCON supplies process plants for separating different types of fluids or fluids from solid material, based on the principles of evaporation, distillation and drying. EPCON has developed unique energy efficient technical solutions for a number of separation and purification processes.

Energy saving

EPCONs core competence is energy utilization in evaporation, distillation and drying processes for a number of applications and industries. Energy savings of 80-98% are normally achieved, within a very favorable investment pay-back time.

Applications in bio gas industry

Typical applications within biogas industry include:

- ❑ Bio gas digestate reject water treatment through a combination of de-gasing, ammonia stripping, pH adjustment, MVR evaporation and drying.

Typical performance values are:

- * COD reduction 95-98%
- * BOD reduction 95-98%
- * N content reduction 95-98%
- * P content reduction 98-99%
- * Ammonia content in ammonia water from stripper is typically 5-7% wt.

If required the condensate can be polished with an ion exchange unit to achieve higher reduction.

- ❑ Other applications within bio gas industry that requires dewatering.

EPCON has experience with the above mentioned applications.

Example biogas reject water treatment without ammonia stripper.

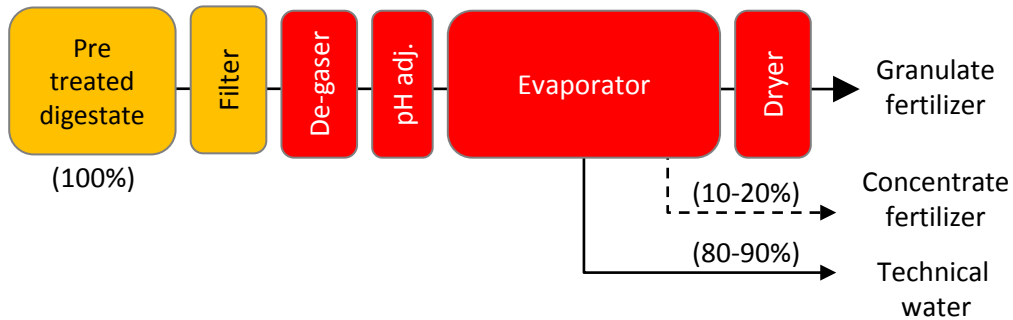

Example biogas reject water treatment with ammonia stripper.

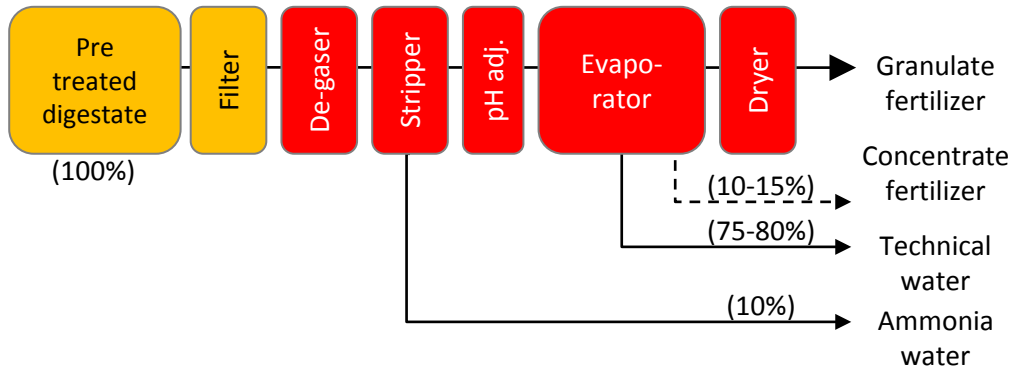

Process route and number of stages may differ from these examples.

EPCON products for biogas applications:

➤ The EPCOVAP-MVR evaporators are a series of standardized compact evaporators with low energy consumption. These are for lower capacity evaporation in the range of 500-2500 kg/h evaporation.



➤ Falling film evaporators with MVR to be tailor made for each specific application. EPCONs falling film evaporators are made for being resistant to fouling. They have a compact design, and hence requires a minimum of space.



➤ Flash coolers for de-gasing of ammonia and other inert gases.



➤ Distillation units for stripping of ammonia using steam.

➤ Combined evaporation plants. The technologies above are often combined to obtain the best technical solution.



Refer the EPCON separate datasheets for further information of the listed process plants.



Case study

Bio gas reject water treatment

A bio gas reject water treatment system was installed in Finland during 2008. The system consist of:

- Flash cooler for de-gasing of inert gases.
- Ammonia stripper for ammonia removal.
- PH adjustment system to bind remaining ammonia as ammonium sulphate.
- MVR evaporator for removal of solids.
- Ion exchange unit to polish the evaporator condensate (not in use)

The evaporator was built as a 3 stage falling film evaporator with integrated cyclone.

Products produced

The following products were produced from the plant:

- **Concentrate** is rich in N and P and is an excellent fertilizer.
- The **clean water** is water of good quality that can be used for technical water, cleaning and similar.
- The **ammonia water** with 5-7% ammonia content is well suited both as a fertilizer as well as nutrient in biological waste water plants where extra N nutrient is needed.



Evaporator during installation



Top of MVR falling film evaporator.

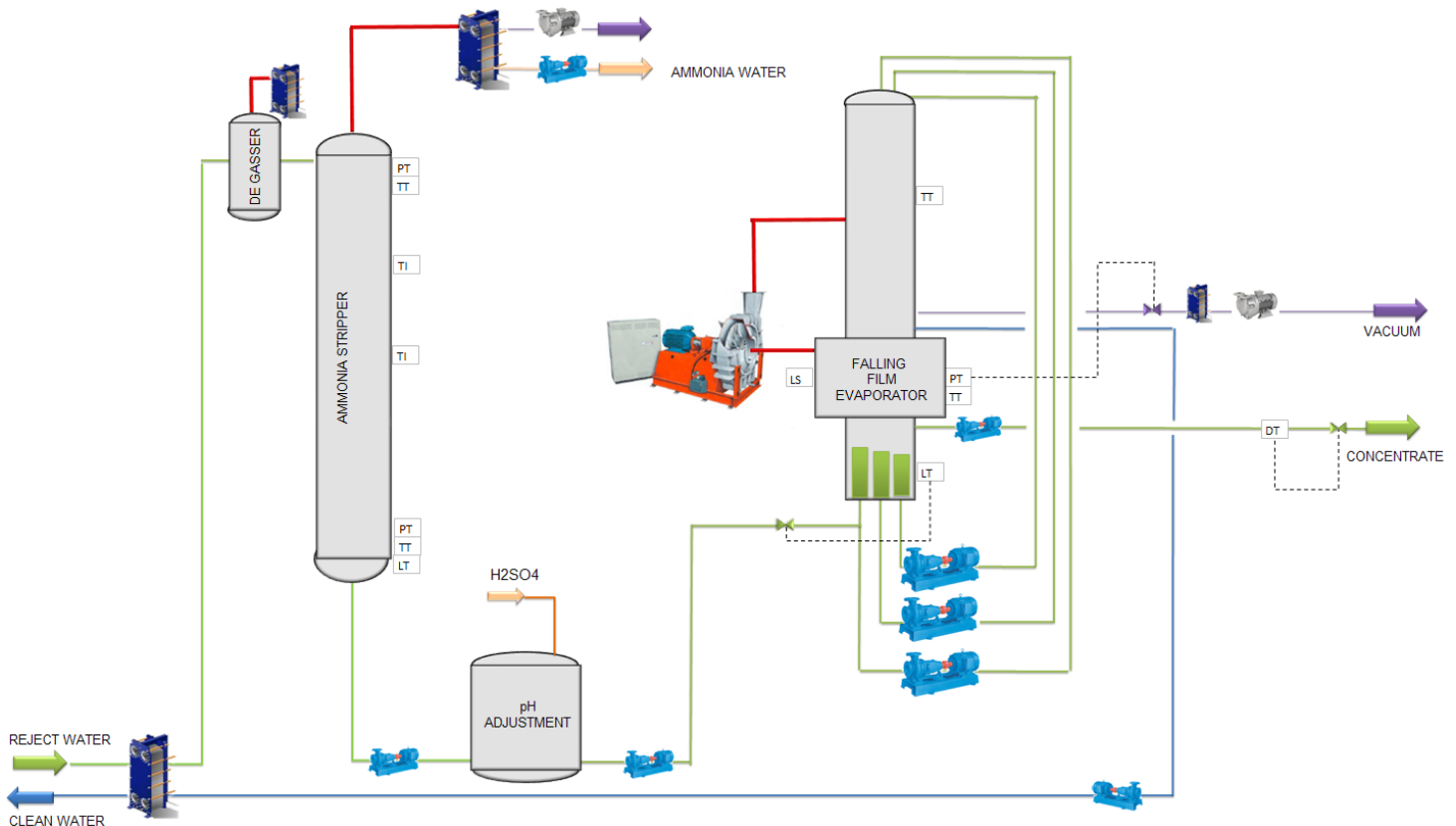

Partners & distributors

Finland

AJON APU OY

Viertotie 3

15560 Nastola

Tel: +358 400 467051

Mail: simo.ajo@phnet.fi

South Korea



5th FL, HP building 23-6,

Yoido-Dong

Youngdeungpo-Gu,

Seoul, Korea, 150-724

Tel: +82-2-2167-9093

Fax: +82-2-2167-9178



Location: Jarleveien 17
Address: N – 7041 Trondheim,
Norway
NO 994 469 126MVA/VAT
Phone: (+47) 73 99 04 50
Fax: (+47) 73 99 04 51
companymail@epcon.org
www.epcon.org