

FORCED CIRCULATION MVR EVAPORATORS



EPCON EVAPORATION TECHNOLOGY AS

EVAPORATORS – DRYERS – DISTILLATION & DEHYDRATION – HEAT RECOVERY SYSTEMS
ENGINEERING AND AFTERSALES SERVICES

Forced circulation or flash evaporator

EPCONs forced circulation or flash evaporator (FCE) is used to concentrate liquids with a high content of dry solids, high viscosity, or for liquids which have a high tendency to fouling and incrustation in other evaporator types.

There is no boiling in direct contact with the heated surface in a flash evaporator, only careful heating at controlled liquid flow rates. This reduces the risk for incrustation and may increase operating times for the plant and eliminate the need for cleaning.

Evaporation takes place by heating the liquid in a heat exchanger that is full of liquid. The pressure in the exchanger is higher than the saturation pressure for the liquid to avoid boiling. The heated liquid is then fed into a chamber where the lower pressure causes the liquid to "flash", thereby emitting vapour to attain equilibrium with the new pressure. The concentration of dry solids in the liquid is increased when the liquid emits water in the form of vapour.

Applications

The EPCON FCE-MVR is a flexible evaporator system that can be used for a wide range of applications including:

- Concentration of steep liquid from sweetener industry.
- Concentration of sweetener products.
- Concentration of stillage from biofuel industry.
- Concentration of marine protein extracts.
- Concentration of ingredients in food industry.
- Concentration of products from chemical and mineral industry.
- Dewatering of wastewater from different industries.
- Regeneration of MEG and PEG.



Fabrication of flash vessels for a forced circulation evaporator

MVR

MVR means Mechanical Vapour Recompression. The vapour from the evaporator is transported with MVR fans, where it is compressed to a higher temperature and pressure. The recompressed vapour is used as a heat source for the evaporation process instead of boiler steam, and will condense on the outside of the vertical tubes in the heat exchanger. The MVR recompression reduces the energy consumption by 90-98% compared to a one effect evaporator.

Evaporator energy consumption: "kWh/ton evaporated mass".

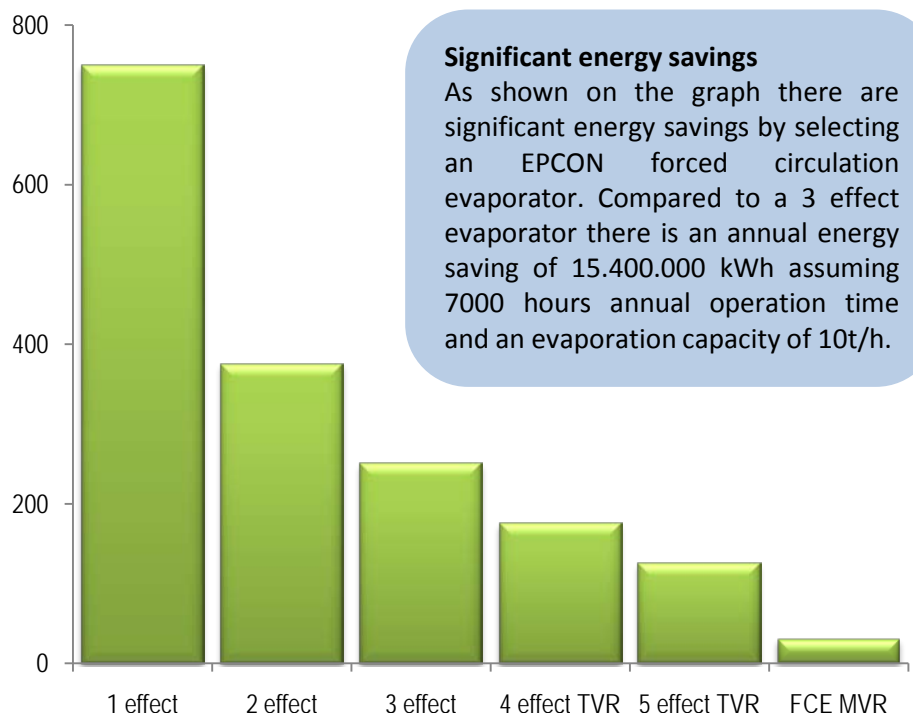

Significant energy savings

As shown on the graph there are significant energy savings by selecting an EPCON forced circulation evaporator. Compared to a 3 effect evaporator there is an annual energy saving of 15.400.000 kWh assuming 7000 hours annual operation time and an evaporation capacity of 10t/h.

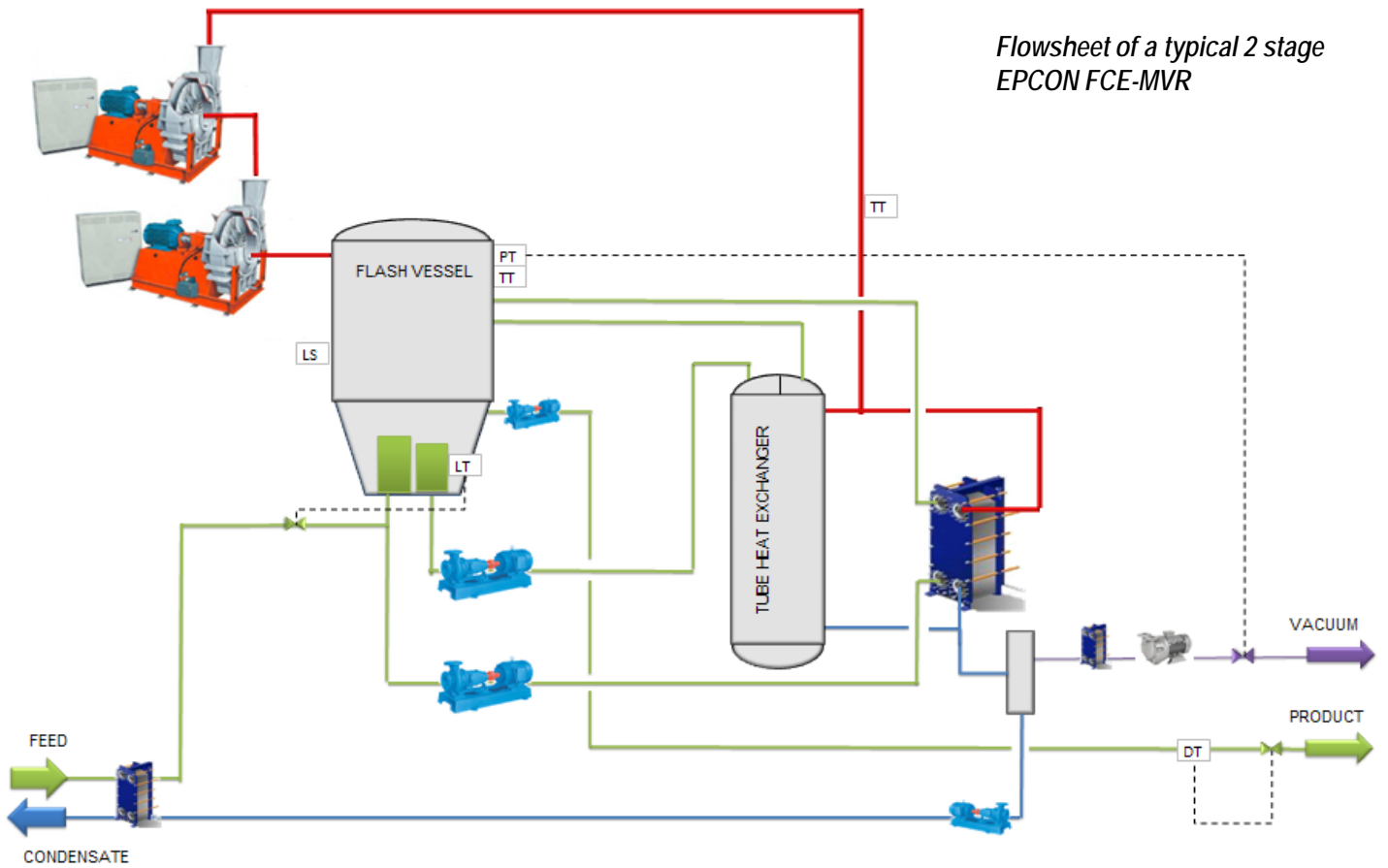

Turnkey plant

EPCON can offer a wide range in scope of supply. Ranging from engineering and main component delivery to turnkey plants.

Application adaption

Each evaporator is tailor-made to the customer's specifications with regards to operating temperature, capacity etc. A wide range of materials and piping standards can be delivered. EPCONs forced circulation evaporators can be manufactured in all sizes. We have designed plants to handle from 10 kg/hour to 200.000 kg/hour evaporated mass.

EPCON FCE pilot plants

EPCON has a wide range of pilot evaporation plants including mobile forced circulation evaporators. These pilot units allow our customers to document and verify the product quality using an EPCON evaporator. The units operate from 40 to 100°C.



Compact design with integrated cyclone

The EPCON forced circulation evaporator has a unique design with an integrated cyclone that require a small footprint.

The pictures above show different EPCON forced circulation evaporators delivered on various locations worldwide.

Partners & distributors

Finland

AJON APU OY

Viertotie 3

15560 Nastola

Tel: +358 400 467051

Mail: simo.ajo@phnet.fi

South Korea



5th FL, HP building 23-6,

Yoido-Dong

Youngdeungpo-Gu,

Seoul, Korea, 150-724

Tel: +82-2-2167-9093

Fax: +82-2-2167-9178

Mail: evapor@sc-eng.com



Location: Jarleveien 17
Address: N – 7041 Trondheim,
Norway
NO 994 469 126MVA/VAT
Phone: (+47) 73 99 04 50
Fax: (+47) 73 99 04 51
companymail@epcon.org
www.epcon.org